

COMBISTORAGE COMBINED SAFETY STORAGE CABINETS
CERTIFIED FOR HAZARDOUS PRODUCTS



COMBISTORAGE

COMBINED SAFETY STORAGE CABINETS CERTIFIED FOR HAZARDOUS PRODUCTS.

The answer to properly store and use hazardous products directly in laboratory.



COMBISTORAGE FIRE TYPE 90



Completely manufactured from 1; 1,5; 2 mm thickness steel sheet, cold pressed, epoxy coated with acid resistant epoxy powders electro-statically applied at a temperature of 200 °C, which ensures a layer thickness higher than 90 microns on the whole surface of the cabinet. Special insulation with rock-wool fiber high density panels 300 kg/m³ (Fiberceramic exempt) resistant to high temperatures (800 °C) and panels of calcium sulphate.

Internal finishing with MFC panels, resistant to acid and corrosive vapours.

Certification TYPE 90 as from last EN 14470-1 NORM and EN 14727.

Standard:

- Automatic door closure in case the ambient temperature exceeds 47 °C.
- Lock with key and door blockage.
- Feet adjustment level.
- 90 minutes certified valves close the ventilation holes when the temperature exceeds 70 °C; one is placed on the rear for extraction.
- Air extraction duct collar 100 mm diam.
- Anti-sparking hinges.
- 3 cm thermo-expanding gasket (DIN 1402).
- **Grounding connection to prevent electrostatic charges.**



COMBISTORAGE CHEMICALS



Completely manufactured from 1; 1,5; 2 mm thickness steel sheet, cold pressed, epoxy coated with acid resistant epoxy powders electro-statically applied at a temperature of 200 °C, which ensures a layer thickness higher than 90 microns on the whole surface of the cabinet.

Internal finishing with MFC panels, WATERPROOF resistant to acid and corrosive vapours.

Certification as from last NORME EN 14727 and EN 61010.

Standard:

- Lock with key and door blockage.
- Feet adjustment level.
- Air extraction duct collar 100 mm diam.
- Anti-sparking hinges.
- **Grounding connection to prevent electrostatic charges.**



COMBISTORAGE UNDERBENCH / 620 H / 720 H



To optimize spaces in laboratory.
Simply replacing the underbench standard
wooden or metal cabinets,
with our combined safety cabinets.



COMBISTORAGE 2, 3, 4 COMPARTMENTS



To safely group all hazardous products in laboratory.



COMBISTORAGE UNDERBENCH / 620 H / 720 H



Numberless options for dimensions and typologies and hazardousness:

INFLAMMABLES, ACIDS and BASES.

If ventilation is needed a vent is on the back wall for easy connection.

Safety underbench cabinets shall be with two different heights:

620 mm
720 mm
+ possible plinth
H **80** mm



E0714AS (395 x 520 x 720 mm)
+ **E0F710** (990 x 520 x 720 mm)



E0FZ120 (plinth 1200 x 500 x 80 mm)
+ **E0716BS** (595 x 520 x 720) + **E0F706D** (595 x 520 x 720 mm)



E0FZ150 (plinth 1500 x 500 x 80 mm)
+ **E0715AC** (495 x 520 x 720) + **E0F706C** (595 x 520 x 720 mm)
+ **E0714BC** (395 x 520 x 720)



E0FZ100 (plinth 1000 x 500 x 80 mm) + **E0F610** (990 x 520 x 620 mm)

COMBISTORAGE FLAMMABLES UNDERBENCH TYPE 90 / 620 H / 720 H



OPENING AND HINGE	CODE FLAM. TYPE 90	EXTERNAL DIMENSIONS L x P x H mm	INTERNAL DIMENSIONS L x P x H mm	CAPACITY BOTTLES 1 LITER FOR CABINET	WEIGHT Kg
500 - RIGHT 	EOF605D	495 x 520 x 620	383 x 349 x 493	12	73
	EOF705D	495 x 520 x 720	383 x 349 x 593	12	78
500 - LEFT 	EOF605S	495 x 520 x 620	383 x 349 x 493	12	73
	EOF705S	495 x 520 x 720	383 x 349 x 593	12	78
500 - DRAWER 	EOF605C	495 x 520 x 620	383 x 349 x 493	12	73
	EOF705C	495 x 520 x 720	383 x 349 x 593	12	78
600 - RIGHT 	EOF606D	595 x 520 x 620	483 x 349 x 493	15	82
	EOF706D	595 x 520 x 720	483 x 349 x 593	15	87
600 - LEFT 	EOF606S	595 x 520 x 620	483 x 349 x 493	15	82
	EOF706S	595 x 520 x 720	483 x 349 x 593	15	87
600 - DRAWER 	EOF606C	595 x 520 x 620	483 x 349 x 493	15	82
	EOF706C	595 x 520 x 720	483 x 349 x 593	15	87
1000 - 2 DOORS 	EOF610	990 x 520 x 620	878 x 349 x 493	27	118
	EOF710	990 x 520 x 720	878 x 349 x 593	27	125
1000 - DRAWER 	EOF610C	990 x 520 x 620	878 x 349 x 493	27	118
	EOF710C	990 x 520 x 720	878 x 349 x 593	27	125
1100 - 2 DOORS 	EOF611	1090 x 520 x 620	978 x 349 x 493	30	134
	EOF711	1090 x 520 x 720	978 x 349 x 593	30	139
1100 - DRAWER 	EOF611C	1090 x 520 x 620	978 x 349 x 493	30	134
	EOF711C	1090 x 520 x 720	978 x 349 x 593	30	139

Add plinth if necessary.

Safety underbench cabinets shall be combined on plinths with different lengths.

CODE PLINTH	DIMENSIONS L x P x H mm
EOFZ40	400 x 500 x 80
EOFZ50	500 x 500 x 80
EOFZ60	600 x 500 x 80
EOFZ70	700 x 500 x 80
EOFZ80	800 x 500 x 80
EOFZ90	900 x 500 x 80
EOFZ100	1000 x 500 x 80
EOFZ110	1100 x 500 x 80
EOFZ120	1200 x 500 x 80
EOFZ130	1300 x 500 x 80
EOFZ140	1400 x 500 x 80
EOFZ150	1500 x 500 x 80
EOFZ160	1600 x 500 x 80
EOFZ170	1700 x 500 x 80
EOFZ180	1800 x 500 x 80



Powder coated metal bottom sump with steel grid.

CODE	FLAMMABLES SHELVES UNDERBENCH	EXTERNAL DIMENSIONS L x P x H mm
RIPF50V	Powder coated metal shelf for FLAMMABLES 500	380 x 330 x 30
RIPF60V	Powder coated metal shelf for FLAMMABLES 600	480 x 330 x 30
RIPF100V	Powder coated metal shelf for FLAMMABLES 1000	875 x 330 x 30
RIPF110V	Powder coated metal shelf for FLAMMABLES 1100	975 x 330 x 30

Standard colour: Grey RAL 7035. Add "Y" to the code for yellow RAL 1021 safety cabinet.

If stainless steel "I" instead of "V".

COMBISTORAGE CHEMICALS UNDERBENCH / 620 H / 720 H



Add plinth if necessary.

OPENING AND HINGE	CODE ACIDS	CODE BASES	EXTERNAL DIMENSIONS L x P x H mm	INTERNAL DIMENSIONS L x P x H mm	CAPACITY BOTTLES 1 LITER FOR CABINET	WEIGHT Kg
400 - RIGHT 	E0140AD	E0140BD	395 x 520 x 620	330 x 430 x 530	18	51
	E0714AD	E0714BD	395 x 520 x 720	330 x 430 x 630	18	54
400 - LEFT 	E0140AS	E0140BS	395 x 520 x 620	330 x 430 x 530	18	51
	E0714AS	E0714BS	395 x 520 x 720	330 x 430 x 630	18	54
400 - DRAWER 	E0140AC	E0140BC	395 x 520 x 620	330 x 430 x 530	9	51
	E0714AC	E0714BC	395 x 520 x 720	330 x 430 x 630	9	54
500 - RIGHT 	E0150AD	E0150BD	495 x 520 x 620	430 x 430 x 530	24	53
	E0715AD	E0715BD	495 x 520 x 720	430 x 430 x 630	24	56
500 - LEFT 	E0150AS	E0150BS	495 x 520 x 620	430 x 430 x 530	24	53
	E0715AS	E0715BS	495 x 520 x 720	430 x 430 x 630	24	56
500 - DRAWER 	E0150AC	E0150BC	495 x 520 x 620	430 x 430 x 530	12	53
	E0715AC	E0715BC	495 x 520 x 720	430 x 430 x 630	12	56
600 - RIGHT 	E0160AD	E0160BD	595 x 520 x 620	530 x 430 x 530	30	55
	E0716AD	E0716BD	595 x 520 x 720	530 x 430 x 630	30	58
600 - LEFT 	E0160AS	E0160BS	595 x 520 x 620	530 x 430 x 530	30	55
	E0716AS	E0716BS	595 x 520 x 720	530 x 430 x 630	30	58
600 - DRAWER 	E0160AC	E0160BC	595 x 520 x 620	530 x 430 x 530	15	55
	E0716AC	E0716BC	595 x 520 x 720	530 x 430 x 630	15	58



CODE	ACIDS SHELVES UNDERBENCH	EXTERNAL DIMENSIONS L x P x H mm
RIPCS140V	Powder coated metal shelf for ACIDS 400	325 x 420 x 30
RIPCS150V	Powder coated metal shelf for ACIDS 500	452 x 420 x 30
RIPCS160V	Powder coated metal shelf for ACIDS 600	525 x 420 x 30
RIPCS100V	Powder coated metal shelf for ACIDS 1000	385 x 420 x 30
RIPCS110V	Powder coated metal shelf for ACIDS 1100	485 x 420 x 30



E0716AD

Standard colour: Grey RAL 7035. Add "Y" to the code for yellow RAL 1021 safety cabinet.

COMBISTORAGE CHEMICAL UNDERBENCH / 620 H / 720 H



Add plinth if necessary.

OPENING AND HINGE	CODE ACIDS + BASES	EXTERNAL DIMENSIONS L x P x H mm	INTERNAL DIMENSIONS L x P x H mm	CAPACITY BOTTLES 1 LITER FOR CABINET	WEIGHT Kg
1000 - 2 DOORS 	E0100AB	990 x 520 x 620	450 + 450 x 430 x 530	18 + 18	104
	E0710AB	990 x 520 x 720	450 + 450 x 430 x 630	18 + 18	110
1000 - DRAWER 	E0100CAB	990 x 520 x 620	450 + 450 x 430 x 530	9 + 9	104
	E0710CAB	990 x 520 x 720	450 + 450 x 430 x 630	9 + 9	110
1100 - 2 DOORS 	E0110AB	1090 x 520 x 620	490 + 490 x 430 x 530	24 + 24	104
	E0711AB	1090 x 520 x 720	490 + 490 x 430 x 630	24 + 24	114
1100 - DRAWER 	E0110CAB	1090 x 520 x 620	490 + 490 x 430 x 530	12 + 12	104
	E0711CAB	1090 x 520 x 720	490 + 490 x 430 x 630	12 + 12	114

CODE	BASES SHELVES UNDERBENCH	EXTERNAL DIMENSIONS L x P x H mm
RIPCS140I	Stainless steel shelf for BASES 400	325 x 420 x 30
RIPCS150I	Stainless steel shelf for BASES 500	452 x 420 x 30
RIPCS160I	Stainless steel shelf for BASES 600	525 x 420 x 30
RIPCS100I	Stainless steel shelf for BASES 1000	385 x 420 x 30
RIPCS110I	Stainless steel shelf for BASES 1100	485 x 420 x 30

Standard colour: Grey RAL 7035. Add "Y" to the code for yellow RAL 1021 safety cabinet.



E0710CAB



E0711AB



EOZF160 (plinth 1600 x 500 x 80 mm)
+ E0716BS (495 x 520 x 720) + E0160AC (495 x 520 x 620 mm)
+ E0F705D (595 x 520 x 720 mm)



Double tightness: prevents the leak of vapours and the entrance of warm air inside in case of fire.



Level adjustment.

COMBISTORAGE 2



Combined safety cabinets certified for the storage of FLAMMABLE products, CHEMICALS, ACIDS and BASES.



E0260



E0360



E0360C

CODE	COMBISTORAGE 2 (SHELVES)	EXTERNAL DIMENSIONS - L x P x H mm
RIPCS260V	Powder coated metal shelf for ACIDS 60	525 x 420 x 30
RIPCS260I	Stainless steel shelf for BASES 60	525 x 420 x 30
RIPF60I	Stainless steel shelf for FLAMMABLES 60	480 x 330 x 30

CODE	DESCRIPTION	EXTERNAL DIMENSIONS L x P x H mm	INTERNAL DIMENSIONS L x P x H mm	SHELVES - QUANTITY AND FINISH	WEIGHT Kg
E0260	Combistorage 2 compartments WITHOUT SUCTION: ACIDS / BASES (door) + FLAMMABLES TYPE 90 (door)	595 x 600 x 1685	530 x 430 x 630 ACIDS / BASES + 483 x 349 x 593 FLAMMABLES	ACIDS & BASES: 1 powder coated metal shelf + 1 stainless steel shelf FLAMMABLES: bottom sump with steel grid	145
E0260C	Combistorage 2 compartments WITHOUT SUCTION: ACIDS / BASES (door) + FLAMMABLES TYPE 90 (drawer)	595 x 600 x 1685	530 x 430 x 630 ACIDS / BASES + 483 x 349 x 593 FLAMMABLES	ACIDS & BASES: 1 powder coated metal shelf + 1 stainless steel shelf FLAMMABLES: bottom sump with steel grid	145
E0360	Combistorage 2 compartments WITH SUCTION: ACIDS / BASES (door) + FLAMMABLES TYPE 90 (door)	595 x 600 x 1685 + 300	530 x 430 x 630 ACIDS / BASES + 483 x 349 x 593 FLAMMABLES	ACIDS & BASES: 1 powder coated metal shelf + 1 stainless steel shelf FLAMMABLES: bottom sump with steel grid	170
E0360C	Combistorage 2 compartments WITH SUCTION: ACIDS / BASES (door) + FLAMMABLES TYPE 90 (drawer)	595 x 600 x 1685 + 300	530 x 430 x 630 ACIDS / BASES + 483 x 349 x 593 FLAMMABLES	ACIDS & BASES: 1 powder coated metal shelf + 1 stainless steel shelf FLAMMABLES: bottom sump with steel grid	170

Standard colour: Grey RAL 7035. Add "Y" to the code for yellow RAL 1021 safety cabinet.

COMBISTORAGE 3



Combined safety cabinet certified for the storage of FLAMMABLE products, CHEMICALS, ACIDS and BASES.



E0343MY11

CODE	COMBISTORAGE 3 e 4 SHELVES	EXTERNAL DIMENSIONS - L x P x H mm
RIP60VMY11	Powder coated metal shelf for FLAMMABLES 60	490 x 420 x 30
RIP60MY11	Stainless steel shelf for FLAMMABLES 60	490 x 420 x 30
RIPCS60	Powder coated metal shelf for ACIDS / TOXICS	550 x 480 x 30
RIPX60	Stainless steel shelf for BASES	550 x 480 x 30



E0342MY11



E0344MY11

COMBISTORAGE 4



Combined safety cabinets with solid and glass doors certified for the storage of FLAMMABLE products, CHEMICALS, ACIDS, BASES and TOXICS.

CODE	DESCRIPTION	EXTERNAL DIMENSIONS L x P x H mm	INTERNAL DIMENSIONS L x P x H mm	SHELVES - QUANTITY AND FINISH	WEIGHT Kg
E0343MY11	COMBISTORAGE 3 solid doors compartments	1200 x 600 x 1950	496 x 446 x 1540 FLAMMABLES + 590 x 500 x 880 x 2 (ACIDS + BASES)	ACIDS: 2 powder coated metal shelves BASES: 2 stainless steel shelves FLAMMABLES: 3 powder coated metal shelves + 1 bottom sump with steel grid	310
E0342MY11	COMBISTORAGE 4 solid doors compartments	1200 x 600 x 1950	496 x 446 x 1540 FLAMMABLES + 3 x 590 x 500 x 580 (ACIDS + BASES + TOXICS)	ACIDS: 2 powder coated metal shelves BASES: 2 stainless steel shelves TOXICS: 2 powder coated metal shelves FLAMMABLES: 3 powder coated metal shelves + 1 bottom sump with steel grid	313
E0344MY11	COMBISTORAGE 4 glass doors compartments	1200 x 600 x 1950	496 x 446 x 1540 FLAMMABLES + 3 x 590 x 500 x 580 (ACIDS + BASES + TOXICS)	ACIDS: 2 powder coated metal shelves BASES: 2 stainless steel shelves TOXICS: 2 powder coated metal shelves FLAMMABLES: 3 powder coated metal shelves + 1 bottom sump with steel grid	315

Standard colour: Grey RAL 7035. Add "Y" to the code for yellow RAL 1021 safety cabinet.

COMBISTORAGE 120 IC FIRE TYPE 90



Combined safety cabinet certified 90 minutes for the storage of FLAMMABLE products, CHEMICALS, ACIDS and BASES.

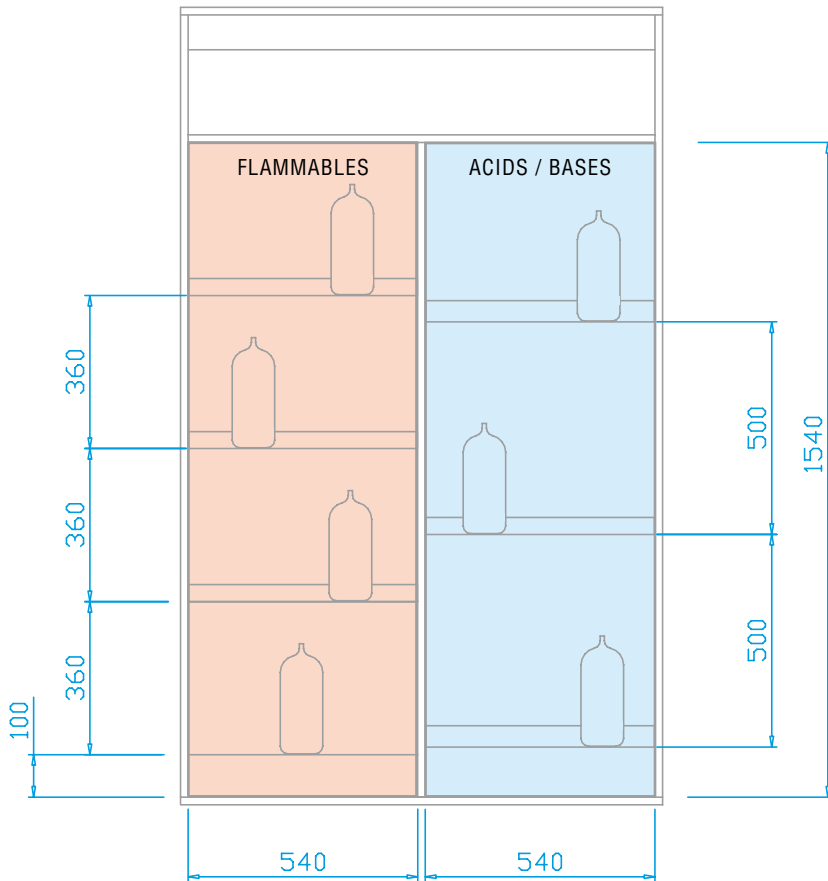

CODE	COMBISTORAGE 120 IC, 120 IAB, 120 IABT SHELVES	EXTERNAL DIMENSIONS - L x P x H mm
RIP60VMY11	Powder coated metal shelf for FLAMMABLES 60	490 x 420 x 30
RIP60MY11	Stainless steel shelf for FLAMMABLES 60	490 x 420 x 30
CSF85P	Stainless steel shelf for BASES	536 x 420 x 39
CSF45P	Powder coated shelf for ACIDS and TOXICS	536 x 420 x 39

CODE	DESCRIPTION	EXTERNAL DIMENSIONS L x P x H mm	INTERNAL DIMENSIONS L x P x H mm	SHELVES - QUANTITY AND FINISH	WEIGHT Kg
EOF232/2C	COMBISTORAGE 120 IC FIRE TYPE 90	1200 x 600 x 1950	1090 x 446 x 1540	FLAMMABLES: 3 powder coated metal shelves + 1 bottom sump with steel grid ACIDS / BASES: 3 powder coated metal shelves	378
EOF232/3C	COMBISTORAGE 120 IAB FIRE TYPE 90	1200 x 600 x 1950	1090 x 446 x 1540	FLAMMABLES: 3 powder coated metal shelves + 1 bottom sump with steel grid ACIDS: 2 powder coated metal shelves BASES: 2 stainless steel shelves	378
EOF232/4C	COMBISTORAGE 120 IABT FIRE TYPE 90	1200 x 600 x 1950	1090 x 446 x 1540	FLAMMABLES: 3 powder coated metal shelves + 1 bottom sump with steel grid ACIDS: 2 powder coated metal shelves BASES: 2 stainless steel shelves TOXICS: 1 powder coated metal shelf	378

Standard colour: Grey RAL 7035. Add "Y" to the code for yellow RAL 1021 safety cabinet.

COMBISTORAGE 120 IAB FIRE TYPE 90



Combined safety cabinet certified 90 minutes for the storage of FLAMMABLE products, CHEMICALS, ACIDS and BASES.

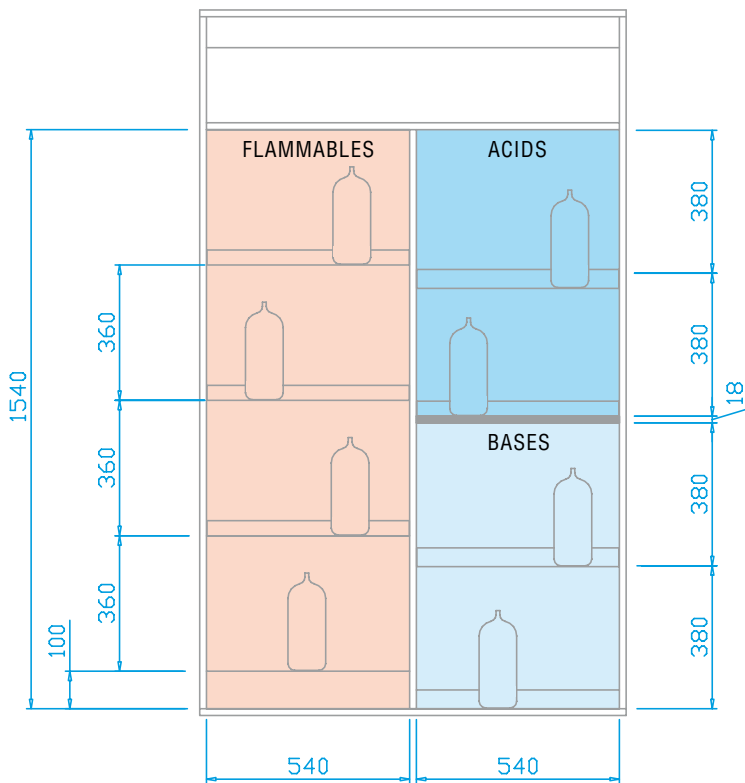

EOF232/3C

COMBISTORAGE 120 IABT FIRE TYPE 90



Combined safety cabinet certified 90 minutes for the storage of FLAMMABLE products, CHEMICALS, ACIDS, BASES and TOXICS.



EOF232/4C

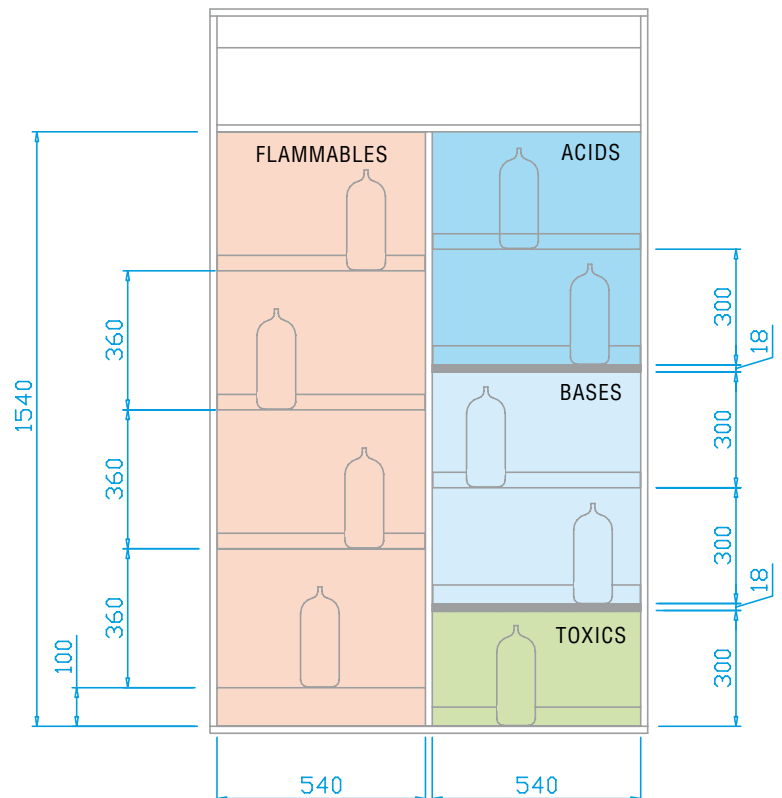

COMBISTORAGE 60 IC FIRE TYPE 90

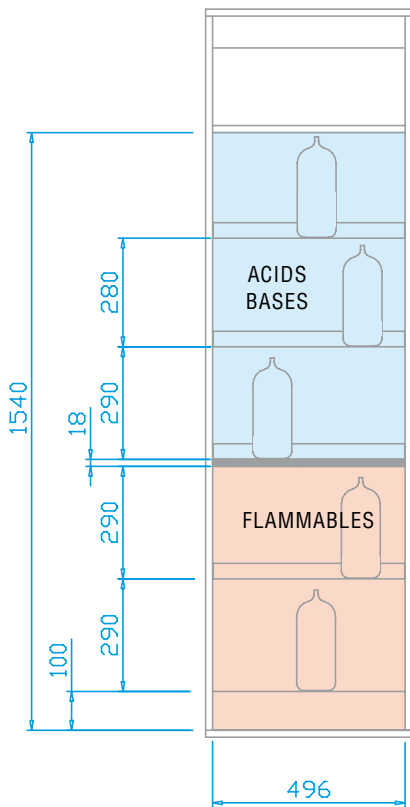

EOF239/2C

Combined safety cabinet certified 90 minutes for the storage of FLAMMABLE products and CHEMICALS.

CODE	COMBISTORAGE 60 IC, 60 IAB SHELVES	EXTERNAL DIMENSIONS L x P x H mm
RIP60VMY11	Powder coated metal shelf for FLAMMABLES 60	490 x 420 x 30
RIP60MY11	Stainless steel shelf for FLAMMABLES 60	490 x 420 x 30
CSF85P	Stainless steel shelf for BASES	536 x 420 x 39
CSF45P	Powder coated shelf for ACIDS and TOXICS	536 x 420 x 39

COMBISTORAGE 60 IAB FIRE TYPE 90



Combined safety cabinet certified 90 minutes for the storage of FLAMMABLE products and CHEMICALS, ACIDS and BASES.

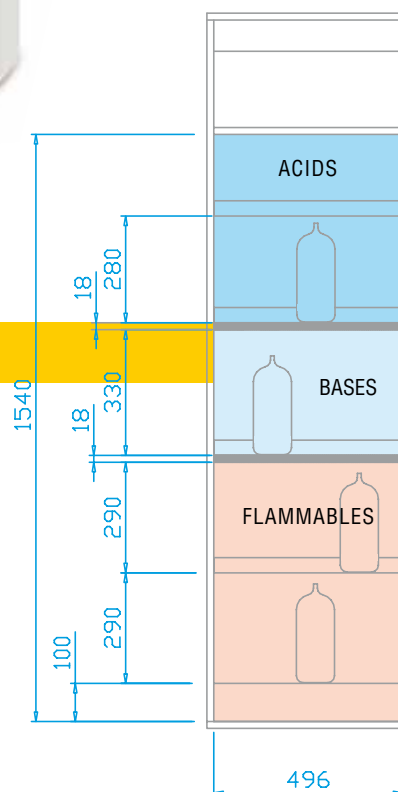

EOF239/3C

CODE	DESCRIPTION	EXTERNAL DIMENSIONS L x P x H mm	INTERNAL DIMENSIONS L x P x H mm	SHELVES - QUANTITY AND FINISH	WEIGHT Kg
EOF239/2C	COMBISTORAGE 60 IC FIRE TYPE 90	595 x 600 x 1950	496 x 446 x 1540	FLAMMABLES: 1 powder coated metal shelf + 1 bottom sump with steel grid ACIDS / BASES: 3 powder coated metal shelves	230
EOF239/3C	COMBISTORAGE 60 IAB FIRE TYPE 90: FLAMMABLE 60 x 60 x 200 H + ACIDS + BASES	595 x 600 x 1950	496 x 446 x 1540	FLAMMABLES: 1 powder coated metal shelf + 1 bottom sump with steel grid ACIDS: 2 powder coated metal shelves BASES: 1 stainless steel shelf	232

Standard colour: Grey RAL 7035. Add "Y" to the code for yellow RAL 1021 safety cabinet.

VENTILATION SYSTEMS AND EXHAUST



EOF100BPMY11



EOF120MY11



CFN

CODE	DESCRIPTION	DIMENSIONS L x P x H mm
EOF100BPMY11	NON-SPARKING EXTRACTION SYSTEM in metal box ON / OFF fuses power cable, filter box	270 x 260 x 430
EOF100ABPMY11	ATEX extraction system in metal box ON / OFF fuses power cable, filter box	270 x 260 x 430
F100	ADAPTATOR SQUARE/round for CSF100BPMY11 and CSF100ABPMY11 for UNDERBENCH	
E0125/100	KIT VENTILATION FOR UNDERBENCH ACIDS AND BASES ON / OFF fuses power cable 220 V - 50 Hz - 13 W - 36 dB - 105 m ³ /h - 28 Pa - Ø 100 mm	
EOF120MY11	CSF120MY11 ventilation unit for COMBISTORAGE 3C and 4C	1200 x 500 x 300
CFN	EXHAUST FILTER/fan module according to NFX 15-211 norm (Filter not included)	550 x 500 x 200
ADMY11CFN	ADAPTATOR for CFN models 3C and 4C	850 x 500 x 80
ADCFNMY11	ADAPTATOR for CFN models COMBI IC, IAB, ABT	600 x 500 x 80
EOAS	CARBON FILTER for SOLVENTS (CFN)	510 x 400 x 60
EOBE	CARBON FILTER for ACIDS (CFN)	510 x 400 x 60
EOMP	CARBON FILTER for ACIDS and SOLVENTS (CFN)	510 x 400 x 60
EOPF	PREFILTER (Spare part CFN)	
K89007	CARBON FILTER for CSF100BPMY11	245 x 110 x 20
KIT2A	KIT PIPE to CONNECT 2 CABINETS	
KIT3A	KIT PIPE to CONNECT 3 CABINETS	
GFKIT100	FLEXIBLE PVC PIPE diam. 102 mm complete with 2 CLAMPS	

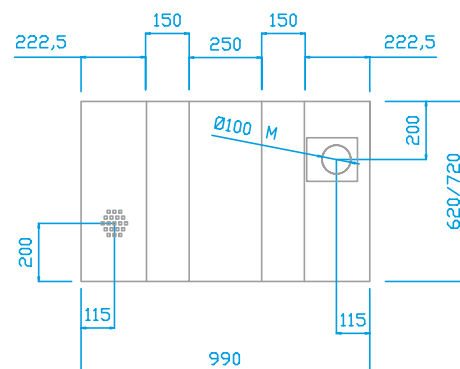
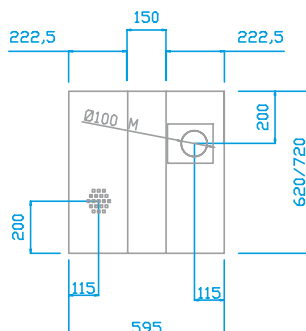
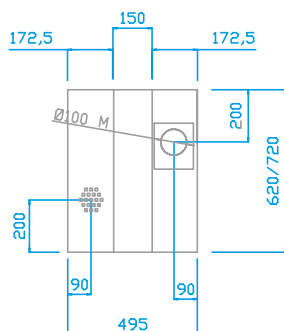
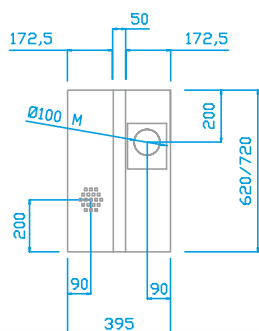

- 1 New closing system which allows to keep the doors open in any position. Automatic door closing in case the ambient temperature exceeds 50 °C.
- 2 Ventilation system diam. 100 mm.

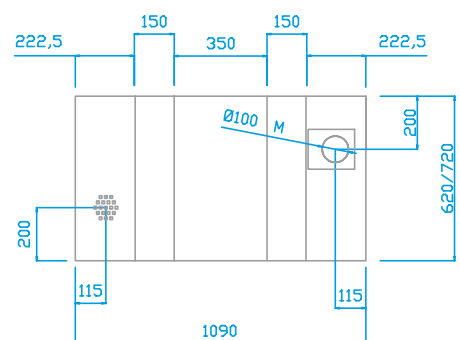

COMBISTORAGE UNDERBENCH FIRE TYPE 90

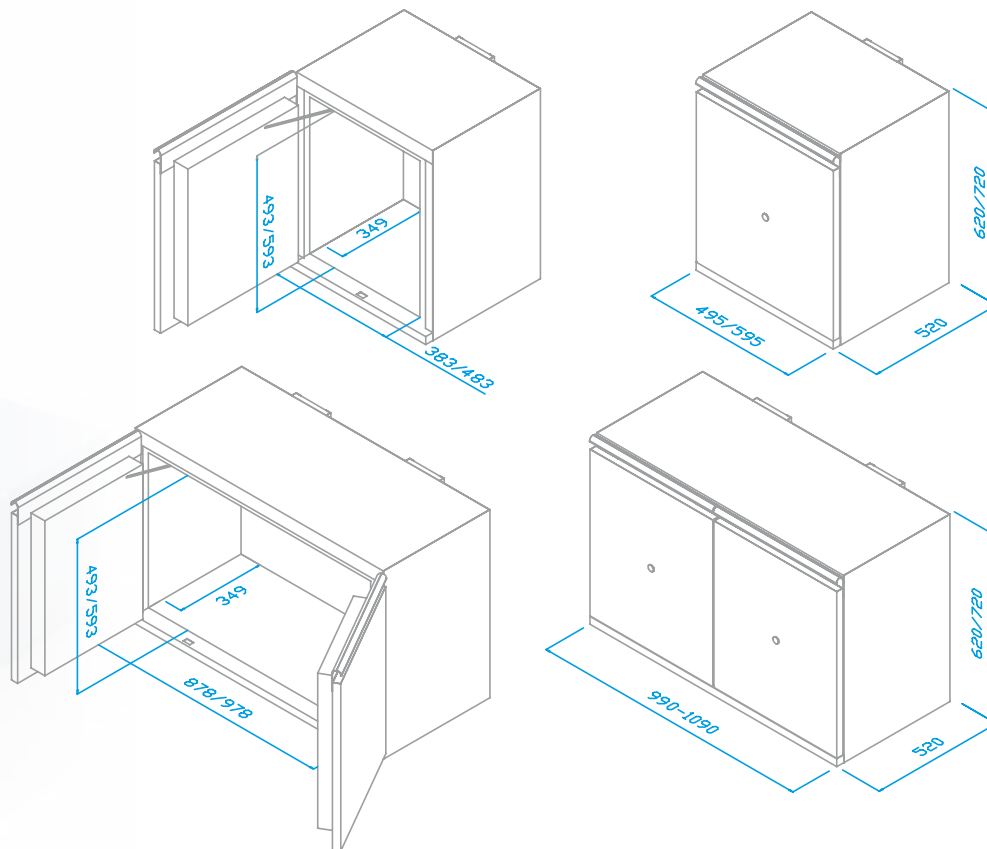

COMBISTORAGE CHEMICALS UNDERBENCH

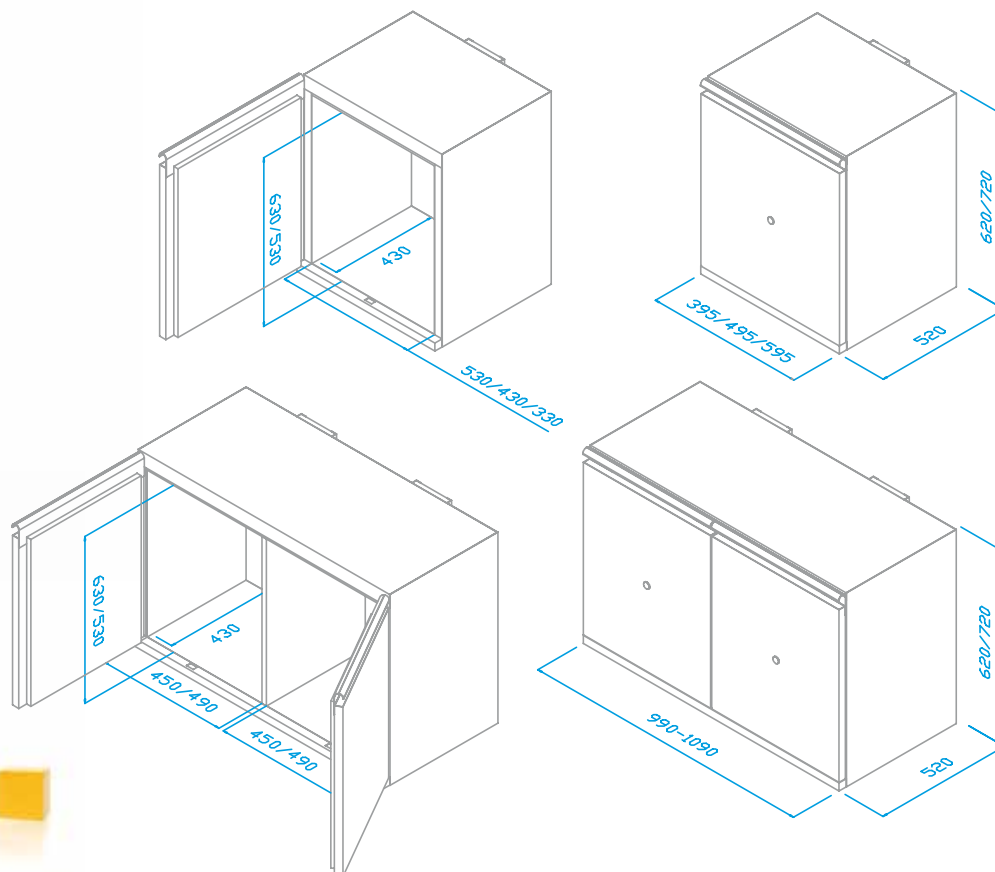

COMBISTORAGE 60 and 120

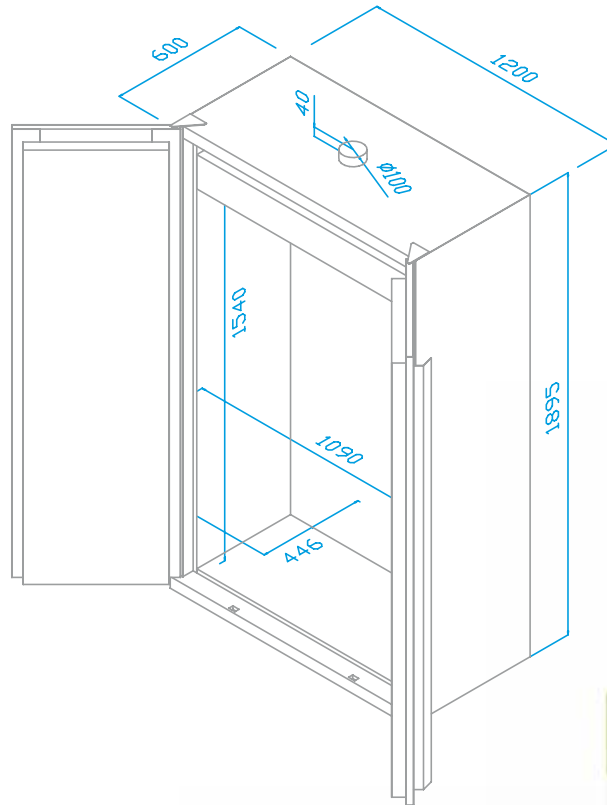
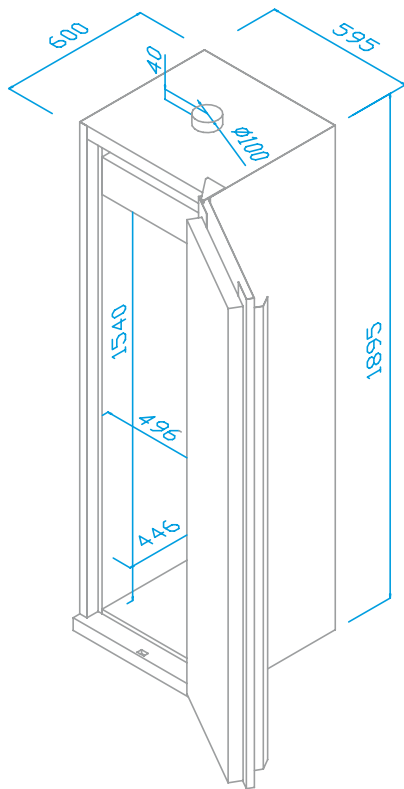

COMBISTORAGE 2

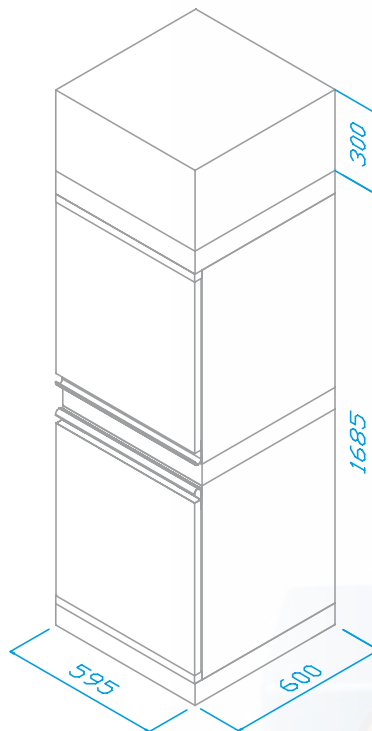
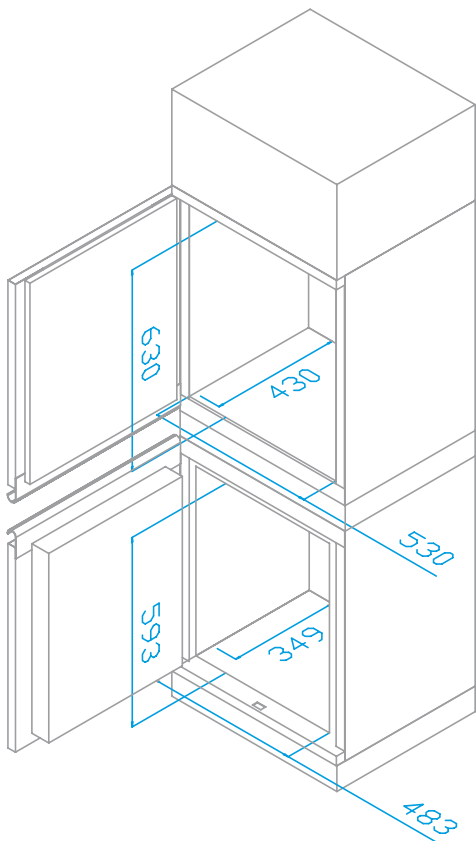

COMBISTORAGE

COMBINED SAFETY STORAGE CABINETS
CERTIFIED FOR HAZARDOUS PRODUCTS



Authorized dealer: